

Project Name: _____
 Location: _____
 Engineer: _____
 Submitted to: _____
 Submitted by: _____
 Reference: _____

Approval: _____
 Date: _____
 Construction: _____
 Unit #: _____
 Drawing #: _____

Performance

Indoor Unit Model No: Non-Ducted
Outdoor Unit Model No: 2MXS18GVJU
Rated Cooling Capacity (Btu/hr): 18000
Sensible Capacity (Btu/hr): N/A
Max/Min Cooling Capacity (Btu/hr / kW): databook/databook
Cooling Input Power (kW): _____
SEER: 19.5
Rated Heating Capacity (Btu/hr): 22000
Max/Min Heating Capacity (Btu/hr / kW): databook/databook
Heating Input Power (kW): _____
Heating COP (Btu/hr / Btu/hr): 3.4
HSPF: 9.2

Indoor Unit Type: _____
Condensing Unit Type: 2 Zone Multi Heat Pump
Rated Cooling Conditions Indoor: 80°F DB/67°F WB
 Outdoor: 95°F DB/75°F WB
Rated Heating Conditions Indoor: 70°F DB/60°F WB
 Outdoor: 47°F DB/43°F WB
Rated Piping Length(ft) 25
Rated Height Separation(ft) 0

Indoor Unit Details

Power Supply (V/Hz/Ph): N/A
Power Supply Connections: _____
Min Circuit Amps MCA (A): _____
Max Overcurrent Amps MFA (A): _____
Dimensions (HxWxD): N/A
Panel (HxWxD): N/A
Net Weight (lbs): _____
Weight with Panel (lbs): _____

Airflow Rate (CFM wet coil) N/A
Moisture Removal (pt/h): _____
Gas Pipe Connection (inch): _____
Liquid Pipe Connection (inch): _____
Condensate Connection (inch): _____
Sound Pressure Level (dBA): _____
Sound Power Level (dBA): _____
Static Pressure Rated/Max (inWg) /

Condensing Unit Details

Power Supply (V/Hz/Ph): 208-230/60/1ph
Power Supply Connections: L1, L2, Ground
Min. Circuit Amps MCA (A): 11.1
Max. Overcurrent Amps MFA (A): 20
Max. Starting Current MSC(A): 8.3
Rated Load Amps RLA (A): 7.7
Dimensions (HxWxD): 28-15/16x32-1/2x11-13/16
Net Weight (lbs): 139

Compressor Type: Inverter
Capacity Control Range (%): _____
Airflow Rate (CFM): 1730
Gas Pipe Connection (inch): 3/8 x2
Liquid Pipe Connection (inch): 1/4 x2
Sound Pressure Level (dBA): 51
Sound Power Level (dBA): _____

System Details

Refrigerant Type: R-410A
Holding Refrigerant Charge (lbs): 5.73
Additional Charge (oz/ft): 0.22
Pre-charge Piping (Length ft): 98.4 ft
Max. Pipe Length (Total ft): 164/82 ft

Max. Pipe Length (Vertical ft): 49.2 ft
Cooling Operation Range (°F): 14 - 115
Cooling Range w/Baffle (°F): 14 - 115
Heating Operation Range (°F): 5 - 72
Heating Range w/Baffle (°F): 5 - 72

Project Name: _____
 Location: _____
 Engineer: _____
 Submitted to: _____
 Submitted by: _____
 Reference: _____

Approval: _____
 Date: _____
 Construction: _____
 Unit #: _____
 Drawing #: _____

Dimensional Drawing - Condensing Unit

2MXS18GVJU

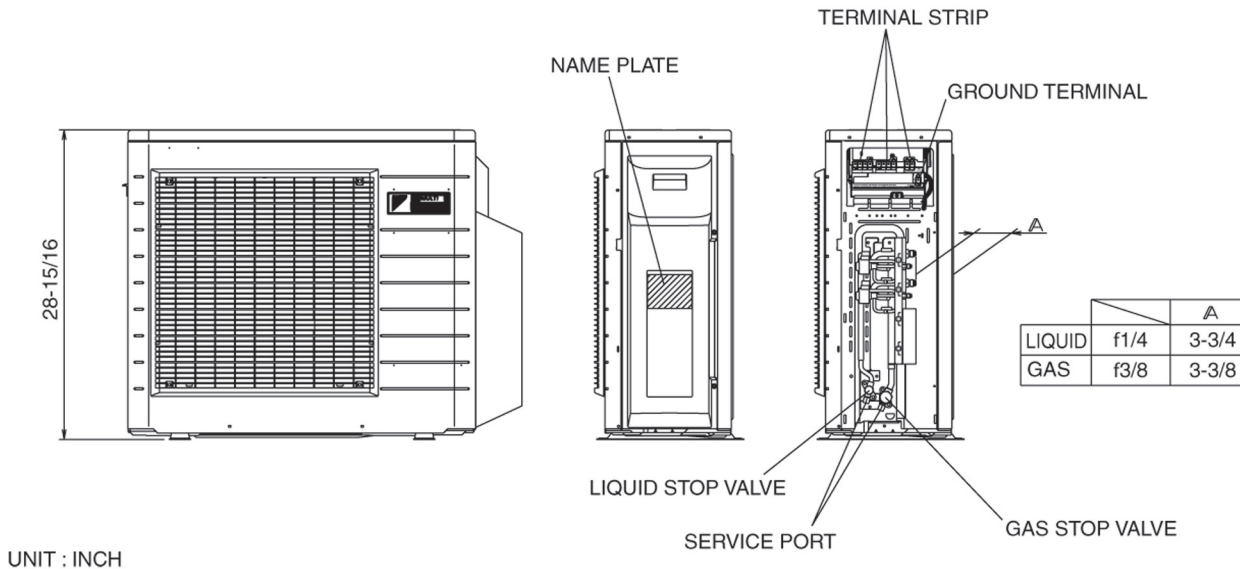
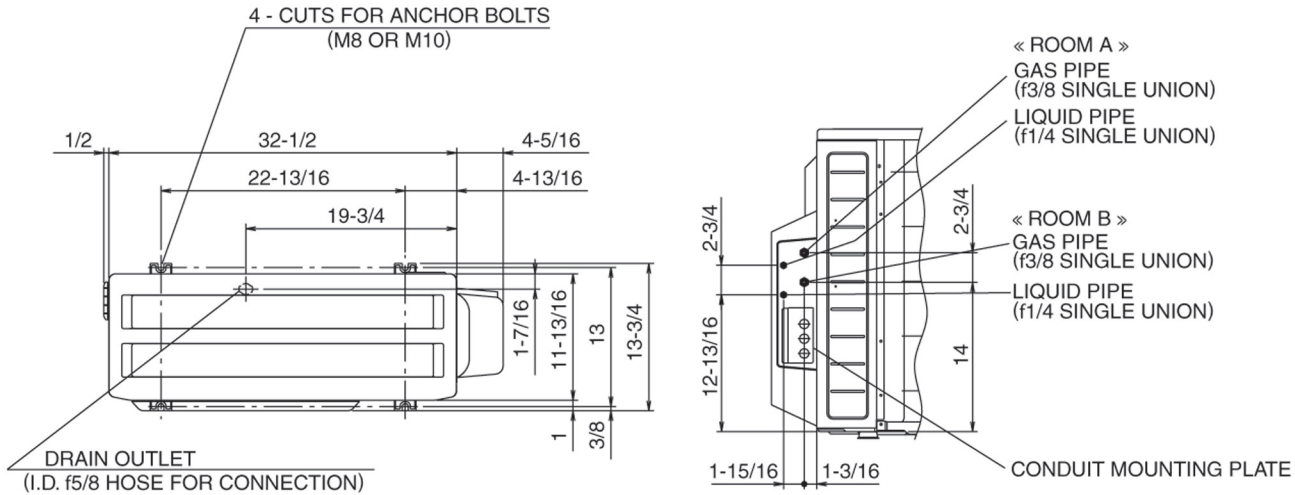

Project Name: _____
 Location: _____
 Engineer: _____
 Submitted to: _____
 Submitted by: _____
 Reference: _____

Approval: _____
 Date: _____
 Construction: _____
 Unit #: _____
 Drawing #: _____

Non-Ducted



Non-Ducted
 Std U.S. Warranty: 7yrs Compressor, 5yrs Parts

2MXS18GVJU
 Std U.S. Warranty: 7yrs Compressor, 5yrs Parts